

DET KGL. DANŠKE VIDENSKABERNES SELSKAB
MATEMATISK-FYSISKE MEDDELELSER, BIND XXII, NR. 4

ON A NEW APPARATUS FOR GAS ANALYSIS

BY

J. A. CHRISTIANSEN AND INGER WULFF



KØBENHAVN

I KOMMISSION HOS EJNAR MUNKSGAARD

1945

Printed in Denmark.
Bianco Lunos Bogtrykkeri A/S

It is well known that gas analysis is widely used in science and industry and especially in the hands of physiologists has been developed to a high degree of precision. But from a constructive point of view the current modern apparatuses, Orsat's for technical gas analysis and HALDANE'S (1) for physiological purposes (respiration studies), in some respects are not quite so elegant as Doyère's apparatus from 1850 (2), the difference being that Doyère used gas siphons and no stop-cocks at all and consequently could avoid any dead space, while both Orsat's and Haldane's apparatuses are based on the use of stop-cocks involving the occurrence of dead spaces. On the other hand it is obvious that the modern apparatuses are faster in operation than Doyère's, and it must be said at once that for technical and many physiological purposes, respectively, the two constructions mentioned will probably retain their dominating positions as standard apparatuses.

Orsat's apparatus usually has a capacity of about 100 ml., while that of Haldane's is designed for quantities of about 10 ml. At the other end of the scale of capacities we have the renowned KROGH (3) burette for quantities from 10 to 100 μ l. and for instance the construction proposed by CHRISTIANSEN (4) and CHRISTIANSEN and HUFFMANN (5) (6) for quantities of a similar order of magnitude, the gap between 100 and 10.000 μ l. remaining uncovered. The aim of what follows is to describe an apparatus covering this gap, i. e. an apparatus with the capacity of about 1000 μ l.

The principle of the above mentioned apparatus of Christiansen and Huffmann may be described as a combined application of Krogh's mercury screw and Doyère's gas siphon with the modification that the siphon is placed on the gas burette,

and not as proposed by Doyère on the absorption pipettes, which renders the construction of these utterly simple.

It seemed obvious that the increased capacity could be reached simply by increasing the dimensions of the different parts of the apparatus, but experiments immediately revealed that operations with these larger quantities of gas required reconstruction of several details, especially the absorption pipettes, to make the absorptions sufficiently fast.

The Gas Burette without Compensator.

The construction of the burette appears from the diagram in fig. 1. It should be mentioned that we have chosen a scale of 400 mm. on the burette as a convenient height, but 500 mm. might be chosen without serious inconvenience.

A is the measuring tube divided in millimetres. The inner diameter of the burette has been chosen at about 1.8 mm., which means a total capacity of about 1000 μ l., and the accessories, especially the absorption pipettes, are designed for this volume. If desired, the capacity may according to calculations be chosen up to 2000 μ l. without redimensioning of the accessories. For a length of 400 mm. a tube of 2.5 mm. diameter contains about 2000 μ l., and as it is sometimes difficult to get capillary tubing of diameters prescribed within narrow limits, a diameter between 1.8 and 2.5 mm., preferably nearer to the former, may be prescribed in ordering the tubing.

The graduated tube is surrounded by water contained in the mantle B equipped with a tube C and a thermometer (not shown in the figure) divided in 0.1° or 0.2° . During the measurements air is bubbled through the water-bath by means of tube C to equalize the temperature. It is advisable to use a rubber stopper at the lower end of the mantle and a cork at the upper end. D is a capillary connected to A by means of a narrow but thick-walled piece of rubber tubing. Care should be taken to make the two glass ends meet inside the tubing. It is essential that D and the narrow tip of A should have nearly the same outer and inner diameters. A convenient outer diameter is about 3 mm. The inner one should be between 0.3 and 0.5 mm. preferably nearer to the former, the idea being that the error arising from

Fig. 1.
The divisions on the burette
are 1 cm. apart, mm's not be-
ing shown in the drawing.
 $\frac{1}{3}$ nat. size.

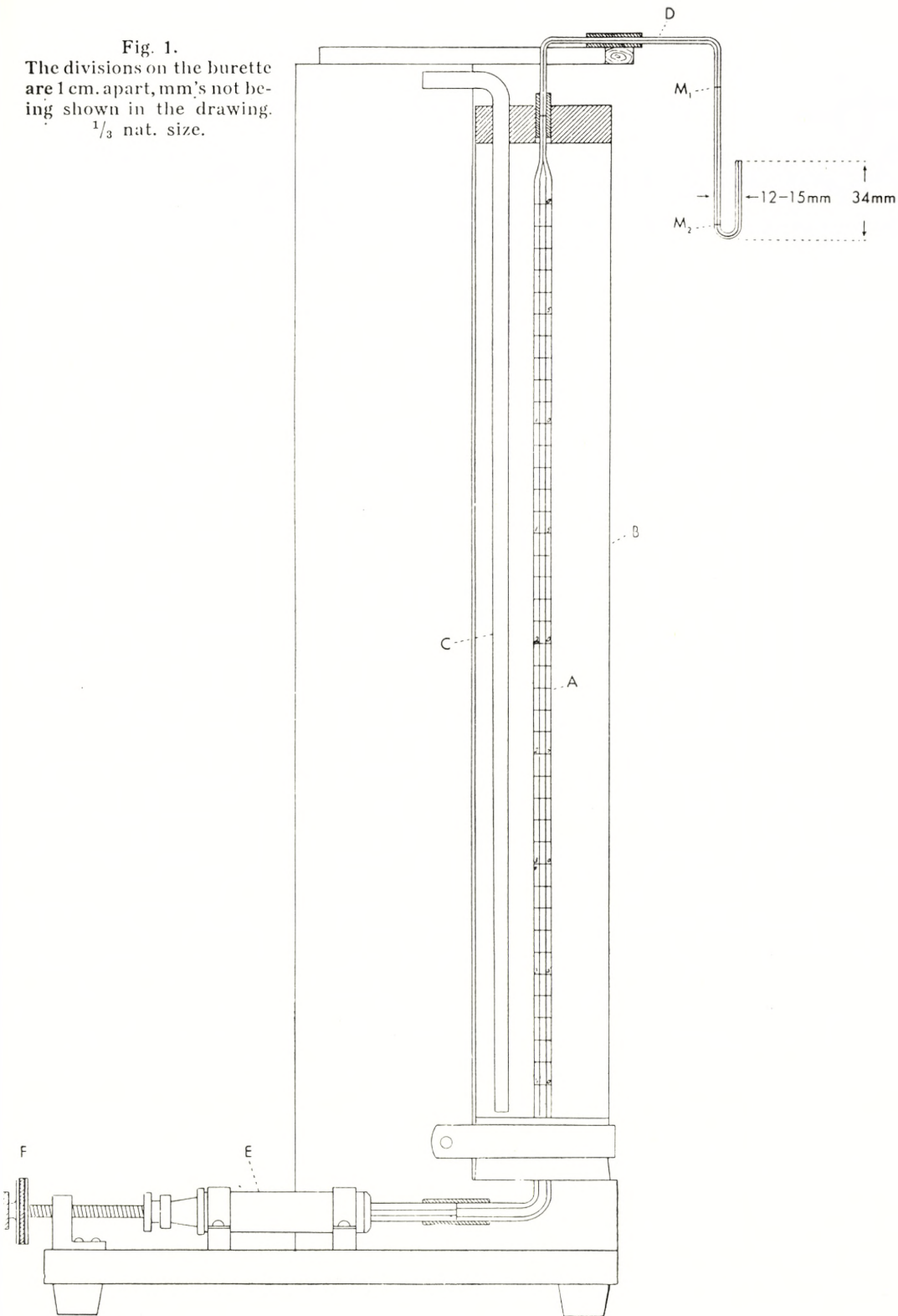

a difference in temperature between D and A of not more than 3° should not amount to more than 0.1 mm. on the scale. Besides it is desirable that D is so narrow that mercury does not enter the siphon too easily, and furthermore that the volume between M_2 and the tip is as small as possible. It may be added that for several obvious reasons it would be preferable to avoid the rubber connection altogether, but according to experience this makes the apparatus a little too rigid and liable to break. D has two marks, M_1 and M_2 , M_1 being conveniently placed 13.7 or 27.4 mm. higher than the tip of D. Usually the gas is confined between a mercury surface in A and a column of water extending to M_1 , so that the volume between zero on the scale and M_1 must be known. Volumes smaller than this may be measured from zero, confined as before between water (meniscus at zero) and mercury.

E is an all-glass syringe connected as shown to the graduated tube by means of stout rubber tubing. Care should again be taken to make the ends meet inside the rubber tubing. If it is intended to use combustion by explosion, a short piece of steel tubing, about 2 cm., must be inserted between the syringe and tube A. The piston should have a diameter between 8 and 12 mm., if shorter, the apparatus is too tedious to operate, if longer, the mercury is apt to move in jumps. It is operated by means of the screw F and a pair of springs, not shown in the figure. Rubber bands may be used, but springs of steel wire are to be preferred.

The apparatus, as shown, is mounted on a wooden support.

The burette is filled with mercury through the siphon by suction with the syringe. By suitable tilting of the whole apparatus and operation of the piston, air bubbles in the syringe are removed. To calibrate the graduations the tip is provided with an inverted U-formed capillary tube, one branch of the U being about twice as long as the other. The short branch is connected to the tip by means of a piece of rubber tubing. The other end is left free. A few μ l. of air followed by a column of mercury is sucked in, and the calibration is performed by weighing mercury sucked in or pressed out, the upper end of the short air column being used as an index. We perform the calibration for whole values of the centimetres and it is recommended to tabulate the corrections on a piece of cardboard. The volumes (expressed in centimetres

on the scale) between zero and M_1 and M_2 and the tip together with the volume in $\mu\text{l.}$ corresponding to 1 cm. on the scale, are tabulated on the same piece of cardboard.

Accessories.

The accessories include an adjustable table and a number of absorption pipettes.

The table must have a maximum height of about 1 cm. below the height from the laboratory desk to the lower bend of the tip D, thus minimizing the risk of breaking the siphon. It is convenient to fix this table on the same base as the burette. The top of the table is preferably rectangular and so mounted that it may easily, although with some friction, be swung round the centre. Its length must be so great, that it nearly touches the mantle B. The breadth may be chosen at about 8 cm. In the vertical direction it must be moved by rack and pinion, length of the movement 8—10 cm.

The absorption pipettes are T-shaped as shown in fig. 2.

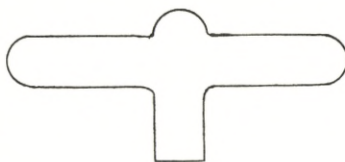

Fig. 2.
 $\frac{2}{3}$ nat. size.

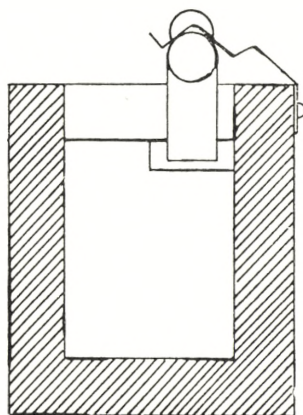

Fig. 3 a.

$\frac{2}{3}$ nat. size.

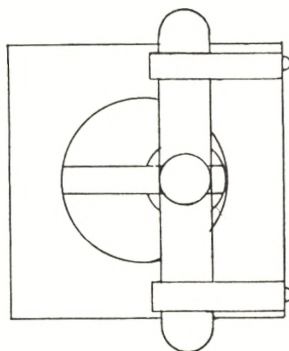

Fig. 3 b.

By means of springs they are placed horizontally on wooden blocks (figs. 3 a, 3 b) 6 cm. high, cross-section 5×5 cm. The blocks are provided with two circular holes, one with its centre in the middle of the block, diameter 3 cm. and depth 1 cm.,

and one eccentric, diameter 1.5 cm., extending 0.5 cm. below the larger hole. As it is convenient always to use a depth of the holes of 1 cm., it is the diameter of the larger hole which determines the capacity. A slit 5 cm. deep reckoned from the upper face of the block is extending from the bottom of the holes. The breadth of this slit is 0.5 cm., just allowing the gas-siphon to pass, and the length 3 cm. This somewhat complicated inner form of the block has been chosen to economize mercury, partly on account of the cost and partly to decrease the weight of the block when filled. For a complete analysis 8 of these pipettes are necessary, viz. 2 for CO_2 , 2 for O_2 , 1 for C_2H_4 , 2 for CO and 1 for explosion or combustion. The pairs for CO_2 and O_2 are necessary because on account of the different compositions of the gases it is not permissible to use the same absorption liquid for the first absorptions of CO_2 and O_2 and for the absorptions after combustion. As, however, it is sometimes desirable to have one or two extra pipettes, one or two spare blocks should be at hand making 10 in all.

In this connection we want to emphasize that we have tried to unite the whole battery of absorption pipettes in one mercury trough, but this proved much less convenient than the use of separate blocks. Besides the blocks with absorption pipettes at least 2 and preferably 3 are necessary as containers for O_2 and the gas to be analyzed, but these must be somewhat larger. We have found the following dimensions convenient: Height of the block 6 cm., cross section 7×7 cm. Depth of the slit 5 cm., breadth 0.5 cm., length 5 cm. Diameter of the holes 5, and 2.5 cm., respectively, depths as described above for the smaller blocks. Of course the T-formed containers must also be larger, preferably with a capacity of about 10—12 ml. But it should be remembered that it must be possible to reach the highest point of the T (the bulb just above the opening) with the gas-siphon.

If it is intended to use the explosion method, one of the smaller containers (the absorption pipettes) must be stoppered inside with a short piece of rubber tubing (0.5—1.0 cm. in length), which just allows the tip of the gas-siphon to pass without or nearly without friction.

Finally 2 or 3 gas containers of the type described by CHRISTIANSEN and HUFFMANN and a small device for filling and

emptying the absorption pipettes are necessary. For the sake of convenience the drawings are repeated here, figs. 4, 5. For sanitary reasons it is recommended to keep objects with uncovered mercury surfaces not in use in a box with a tightly closing lid.

For the explosions an induction-coil is needed. We have used a Ford induction-coil connected through a switch to a 2 volt

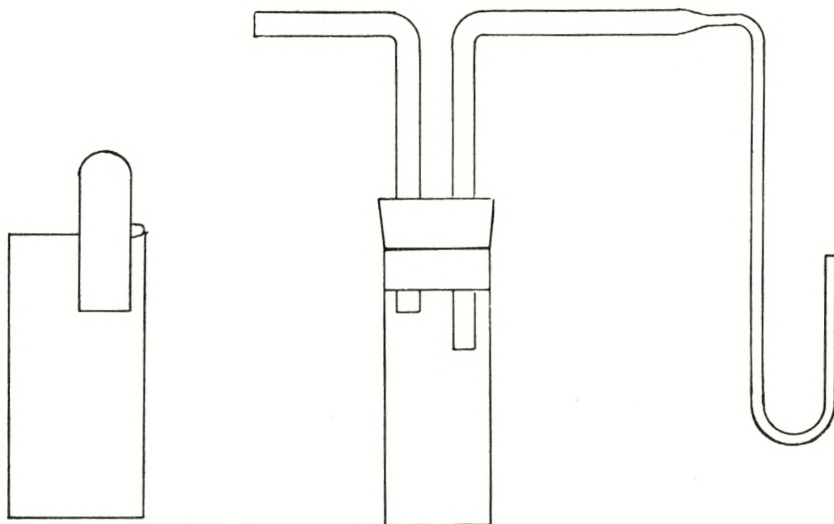

Fig. 4.

 $\frac{2}{3}$ nat. size.

Fig. 5.

accumulator, the oscillator of the coil being put out of action by means of a piece of match. By this means a single spark is produced when the switch is operated once on and off, the spark appearing at the "off" stroke. The high-tension terminal of the induction-coil is connected to the mercury in the graduated tube through the above mentioned short steel tube, while the low-tension terminal binding post is connected to the mercury in the explosion pipette through a steel wire. In this way the tip of the gas-siphon acts as a sparking-plug when introduced just above the mercury surface in the pipette, the terminals being a small globe of mercury made to appear on the tip and the surrounding mercury, respectively.

The operation of the apparatus is as follows: From the T-shaped container a suitable amount of the gas to be analyzed is drawn into the burette and sealed with mercury in the siphon. (It should be noted here, that the tip of the siphon must always

be wet when dipped under dry mercury. If not, a trace of air will be drawn in. The tip should be cleaned at intervals with chromic acid mixture.) Now one of the gas containers (fig. 4) is filled completely with water and placed round the siphon. Air above the outer branch of mercury is expelled and then the tip of the siphon is put into the inverted glass tube (the bell). Next the mercury is expelled, at which it cannot be avoided that some gas escapes into the bell. This is drawn back into the burette and the whole specimen sealed with a column of water. The table is now so adjusted that the tip is on a level with the free surface of the water and the meniscus in the capillary is placed at M_1 , after which the volume is read. It should be noted, that if the gas contains high percentages of relatively soluble gases, such as CO_2 or N_2O , the gas escaping when the mercury is expelled must not be collected as its composition will have changed. On the other hand there is no risk of serious errors by sealing even mixtures rich in those gases with water in the narrow tubing of the siphon on account of the small surface involved. It is mainly for this reason, that adjustment of the water meniscus at M_1 and not at the zero mark of the burette proper is to be preferred.

Next the absorptions are brought about in the usual order.

As absorption liquids we recommend: For CO_2 : a solution of 50 g. KOH in 50 ml. of water. For O_2 a solution of 10 g. $Na_2S_2O_4$ and 7 g. KOH in 50 ml. of water.

For C_2H_4 : 100 per cent. H_2SO_4 , which does not seriously attack mercury, while fuming acid (containing $H_2S_2O_7$) evolves SO_2 . 100 per cent. H_2SO_4 is easily prepared by mixing ordinary conc. H_2SO_4 with fuming acid in suitable amounts. It is tested by means of the melting point, which should be $+9^\circ$ or higher.

For CO the ammoniacal solution of CuCl known from macro gas-analysis must be used, as the acid solution attacks mercury. As is well-known, two pipettes of this reagent must be used in series, when considerable amounts of CO are to be expected. It must be said that immediately after the use of this solution it is sometimes necessary to clean tube D with water, conc. sulphuric acid, and water in the order mentioned.

The absorption pipettes are filled somewhat less than half with the solutions. As they are stored over mercury there is no

danger of their deteriorating by contact with air. For this reason the CO_2 and CO reagents keep indefinitely when not in use. But the O_2 -reagent is intrinsically unstable and must be renewed at intervals and the pipette with 100 per cent. H_2SO_4 should be emptied as soon as circumstances permit. For the absorptions the gas is transferred to the pipette and absorption effected by suitable rhythmic shaking of the block. The gas-siphon is not removed during this operation. The CO_2 -absorption is very fast, 30 strokes (about 30 sec.) being amply sufficient. The velocity of the O_2 -absorption depends on the age of the reagent. If 200 strokes (about 2—3 min.) do not suffice it will be convenient to renew the reagent. The C_2H_4 - and CO -reagents seem to work somewhat faster than the O_2 -reagent and the user is advised to work out for himself the times necessary for the different absorptions.

After the absorption the gas is drawn back into the burette, the last part collecting as a small bubble in the bulb just above the tip of the siphon, where it is easily caught and drawn into the burette. It must be avoided to get detached drops of the liquid into the siphon. At last the gas is sealed with the absorption liquid, the absorption pipette removed from the siphon, and one of the containers (fig. 4) filled with water placed with the bell around the tip. By operating the screw the absorption liquid is replaced by water and the capillary washed several times to remove traces of the liquid. Any gas bubbles lost during these operations collect in the top of the bell and are easily drawn back without any detached drops of water in the gas column. The volume is read as at the reading of the original volume.

If there is any reason to suppose that the rest after the absorptions contains combustible gases (H_2 and CH_4), it is collected in the explosion pipette and mixed with a measured amount of oxygen. After the measurements both gases (the rest and the added O_2) are sealed with columns of water extending only from M_2 to the tip of the siphon. The explosion is brought about as described above. Usually it occurs at the first spark; if not, the reason probably is that the mixture is not explosive. In that case a measured amount of hydrogen is added and the explosion thus effected. It may, however, happen that the spark gap is short-circuited by a drop of water adhering to the tip. In that case the explosion pipette is raised a little so that the tip dis-

appears under the mercury. The water drop then remains on the mercury surface, just above the tip, from where it is removed by shaking the pipette.

After the explosion the gas is drawn back into the burette, by which operation first the gas, next, most of the water (twice the volume contained between M_2 and the tip) and finally some mercury as sealing liquid passes the siphon. To replace the mercury by water (this is necessary as it has proved too difficult in the long run to use mercury as confining liquid) the siphon is introduced into a container (fig. 4) filled mainly with mercury, but with a small amount of water, about 5 mm. in height, on the top of it. The mercury is now pressed out, some gas also escaping into the bell. This is united with the main portion in the burette and sealed with water.

With gases rich in CH_4 this operation is the only one which is a little difficult, as it is essential here that the gas bubble in the bell should be in contact with the water for the shortest possible time on account of the risk of loss of CO_2 by absorption. For the same reason it is recommended to saturate the water over the mercury in the bell with the gas resulting after explosion from the first analysis, whose result is then disregarded, and to repeat the analysis with the same ratio between gas and added oxygen.

After the sealing with water the bell with mercury is replaced by the one with water and the volume read as before.

During this replacement it sometimes happens that mercury enters the tip of the siphon, which is very inconvenient as it necessitates the repetition of the operation. If the siphon is not too wide this can be remedied by reducing the difference in level between the outer and the inner surface of mercury in the water-containing bell.

When only one of the gases H_2 or CH_4 is present, the analysis may be considered as finished; if not, and if an independent control is wanted, first CO_2 and then O_2 are absorbed as above. As the compositions of the remaining gases are completely different from those at the first absorptions of CO_2 and O_2 , a second set of absorption pipettes should be at hand.

It is a matter of course that the most scrupulous cleanliness must be observed at the filling of the absorption pipettes and

at all the operations, especially the washings of the siphon after the absorptions and before the combustion, as traces of alkali remaining in the capillary or still worse at the rubber connections,

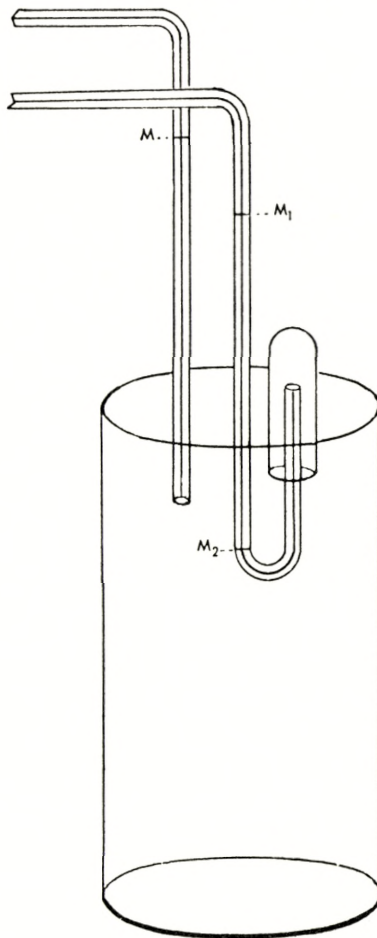

Fig. 6.
 $\frac{2}{3}$ nat. size.

if any, may give rise to serious errors in the CO_2 -determination after combustion. On the other hand this danger should not be exaggerated, and care taken to avoid unnecessary time-consuming manipulations. F. inst. we have found by experiment that in working with the burette with compensator, which necessitates the use of an especially large wash-beaker (see fig. 6), there is no objection to using the same wash-water for one complete analysis. We add that we take advantage of the fact that the

absorption liquid has specific gravities exceeding that of water, so that water layers a few millimetres above the tip are practically pure even if concentrated KOH solution has recently passed out. Concerning the filling of the pipettes with the absorption liquids the siphon (fig. 5) used for this purpose should be cleaned with chromic acid mixture just before use, as traces of impurities (grease?) suffice to alter the surface conditions inside the pipette so that the gas splits up into bubbles, which do not unite before a certain lapse of time, making the withdrawal from the pipette into the burette a rather time-consuming procedure. Of course also the flasks containing the absorbents should be held scrupulously clean.

For specimens rich in combustible gases we have found the explosion method convenient on account of its rapidity, and with access to pure hydrogen it may of course be used in all cases. But in the case of small contents of combustible gases the result becomes uncertain, the final result being a small difference between relatively large quantities.

It should be added that the explosion method has a still more serious drawback, as one must be careful to ascertain that no oxidation of nitrogen takes place. This can be attained by increasing the amount of oxygen, but if the gas specimen is too small to allow a second analysis to be performed, this is inconvenient. If rapidity is not essential, we therefore recommend slow combustion in a heated quartz capillary. In this way oxidation of nitrogen is avoided and the method has this further advantage that combustible gases are burnt, however small their concentrations.

For this purpose a hairpin-shaped quartz capillary (about 0.5 mm. inside diameter, the branches being 50 mm. long) is inserted on the top of the burette or on a separate combustion pipette by means of rubber tubing. Here, too, the siphon is preferably made from quartz, but we have found it sufficient to use a second rubber connection to the glass siphon about the middle of its horizontal part. To heat the "hairpin" a small removable electric furnace wound from nichrome wire on an unglazed porcelain tube (about 10 mm. inside diameter) on a length of about 50 mm. and insulated with two or three layers of asbestos card is recommended. Our furnace uses 1 amp. at 50 volt, this

giving a bright yellow heat. If the apparatus is intended to give the highest attainable accuracy of the absorptions, it is preferable to use a separate pipette for the combustion as the insertion of the quartz capillary between the burette proper and the gas-siphon increases the volume containing gas at an ill-defined temperature. The use of a separate combustion pipette of course necessitates an extra transfer of the gas, thus increasing the duration of the analysis by about 1 min., which is not very essential. It is more important that it is cheaper to mount the "hairpin" and the furnace on the same support as the burette, thus avoiding not only the extra support but also an extra glass syringe and generally making the apparatus more compact. Fig. 7 shows the construction of the separate combustion pipette. It has a quartz hairpin made in one piece with the siphon. Outer and inner diameters of the capillary are as usual 3 mm. and 0.3—0.5 mm., respectively. It may be remarked that we have been unable to purchase quartz capillaries with inside diameters less than 0.5 mm. If desired, f. inst. after a break, the siphon may be made of glass from G to the tip, the glass and quartz capillaries being connected by means of rubber tubing. If necessary, the ends are ground fairly plane by means of a file or a carborundum stone.

The tube H of a capacity somewhat larger than the burette serves as gas container at the operation. I is the furnace wound on the end of the unglazed porcelain tube (inside diameter 10 mm.). The tube is cramped in one end of the wooden bar K, the other end of which is fastened on the brass tube L, through which the electric leads for the furnace pass. This tube is so mounted on the back of the wooden stand that it may be swung round its axis and lifted about 6 cm. so as to allow the furnace to be placed round the hairpin and to be removed after use. Suitable stops prevent undesired movements of the furnace.

For the combustion the gas mixed with oxygen is collected in the explosion pipette, after which the combustion is performed by screwing the mercury backwards and forwards some times, the minimum number, usually about 4, being determined by experiments. If the quartz capillary is narrow enough, explosions hardly occur, even with strongly explosive mixtures. Further-

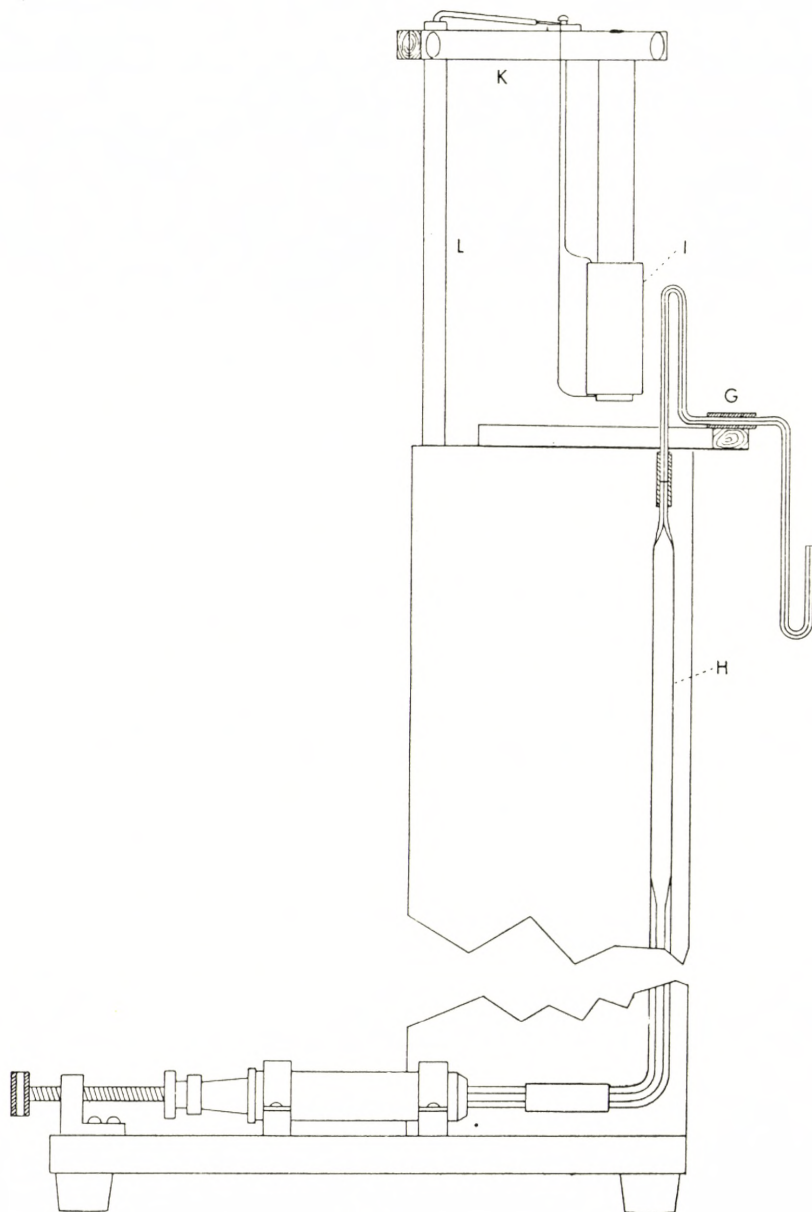

Fig. 7.
 $\frac{1}{3}$ nat. size.

more an explosion is harmless, when the stoppered explosion pipette is used as container.

The treatment after combustion is exactly as after an explosion.

It is obvious that the combustion takes more time than the explosion as it is necessary to pass the gas several times through the combustion tube to ensure complete combustion, not to speak of the time of heating and cooling the "hairpin." It is especially difficult to burn the last traces of CH_4 . In this connection it should be mentioned that at first we worked for some time with a platinum capillary about 0.5 mm. inside diameter instead of the quartz tube. But this gave rise to troubles probably arising from spluttering during the combustion. At least they seemed especially to occur after we had tried to fractionate a mixture of H_2 and CH_4 by burning H_2 at low temperatures. These experiments in so far seemed successful, but after we had tried a few times, the flow of mercury through the capillary was rendered more and more difficult and eventually stopped completely. For this reason and of course also on account of its transparency quartz is to be preferred. Concerning the combustion of CH_4 it must be emphasized that it is at least as difficult to burn CH_4 quantitatively in a platinum as in a quartz tube, the only remedy being to choose the highest temperature the furnace will stand.

Calculations.

The principle of the calculations is too obvious to be given here, but a few details may be mentioned. It is of course necessary to reduce the "wet" volumes corrected for errors of calibration to standard conditions. All volumes are preferably measured in centimetres on the scale, as the absolute volumes are of interest in exceptional cases only. If M_1 is placed, as proposed, 13.7 mm. above the tip, the pressure obviously is always 1 mm. less than that read on the barometer. The volume after combustion must be corrected for CO_2 dissolved in the water introduced together with the gas and the oxygen, viz. in twice the volume of water contained between M_2 and the tip. If c is the volume of CO_2 , a the total volume after combustion and w the volume between M_2 and the tip, the correction will be $\left(2 w \cdot \frac{c}{a} 0.942\right)$.

0.942 is the Ostwald solubility of CO_2 in water at 20° . At other temperatures the solubilities are

at 15°	16°	17°	18°	19°	20°	21°	22°	23°	24°	25°
1.074	1.043	1.015	0.989	0.965	0.942	0.920	0.896	0.872	0.850	0.829

The correction thus calculated will be a minimum value as some extra moisture will get into the explosion pipette from the outer surface of the wet gas-siphon.

Accuracy.

The accuracy of the results is about 0.1 per cent. absolute on the absorptions, depending somewhat on the total volume. But of course it should be remembered that the first analysis on a gas mixture can never be quite correct, as saturation of the absorption liquids with the mixture at hand must be accomplished before the results are reliable. The error on the combustion is somewhat greater, especially when a mixture rich in CH_4 is to be analyzed. As far as we have been able to ascertain, the error is chiefly due to the solubility of CO_2 . The correction for dissolved CO_2 mentioned above may easily amount to 2 mm. or more (on the scale), and as the amount of water in the explosion pipette certainly is somewhat greater than that known to be introduced with the gases, it is no wonder that the values for CH_4 (calculated from the CO_2 found after explosion or combustion) always tend to be low. We should say that a defect in CH_4 of 0.5 per cent. on values about 100 per cent. is rather the rule than the exception. By skilful operation and especially by using a large excess of O_2 , thus reducing the CO_2 -content in the gas after combustion, the error may be reduced, but it will be difficult to avoid it completely. For this reason the determination of small amounts of hydrogen in gases rich in methane is nearly impossible. We have made some experiments to ascertain if also oxidation of mercury might play a rôle. To this end we proceeded as follows: A certain amount, about 200 μl . of 10 per cent. KJ solution was measured in the burette, 0.1 n HCl added from a microburette of the REHBERG (7) type, after which the CO_2 was expelled with a stream of CO_2 -free air and the acid titrated back with 0.1 n NaOH, phenolphthalein being used as an indicator. Next, an ex-

plosion was brought about and a similar amount of KJ-solution sucked into the explosion pipette, shaken for a short time and then drawn back and delivered into the beaker used for titration. The rest of the solution was delivered into the same beaker by repeating the operation twice with water and the titration performed as mentioned above.

In this way we performed a series of experiments both with explosions and combustion. We found indications of a slight formation of base according to the equation

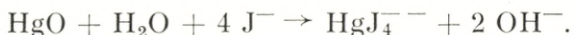

The amount of O_2 consumed by oxidation was rather variable, usually less than $0.4 \mu\text{l.}$, which on our burette corresponded to 0.2 mm. May be the oxidation was slightly greater in the combustion experiments, but on the whole it must be said that an error corresponding to more than 0.2 mm. on our burette is exceptional, an error which is barely perceptible. And even this must be considered as a maximum, as our KJ-solution seemed to attack mercury under formation of base.

The Burette with Compensator.

As is well-known, the reduction of gas volumes to standard conditions is rather time-consuming. F. inst. Haldane's apparatus for that reason is provided with a compensator containing moist air. The same principle was used by L. DOYÈRE (2) nearly a century ago.

We have found it convenient to use it also in our apparatus. To this end the mantle containing the temperature bath is made about 55 mm. wide, the burette and the compensator being placed about 30 mm. apart. The water in the bath must be stirred continually by means of air bubbles during the analysis.

The compensator is a glass tube, whose inner diameter is not important, about twice the inner diameter of the burette being suitable. At the upper end it is constricted to about $0.3\text{--}0.5 \text{ mm.}$ inside and about 3 mm. outside diameter. At the lower end it is somewhat extended so as to accomodate a mercury screw according to A. Krogh (a hard rubber nut with a steel screw about 3 mm. in diameter). The mercury screw is made

mercury-tight by means of tap grease and is cemented into the glass tubing by means of picein or de Khotinsky cement. It is covered with mercury and a few drops of water. By means of rubber tubing the upper end is connected to a narrow glass tube similar to the one used at the top of the burette, only without the part from M_2 to the tip. For use the narrow tube is cleaned with chromic acid mixture, which is drawn in and squeezed out by means of the mercury screw and afterwards cleaned by water. We recommend this to be done immediately before the start of a series of analyses. By suitably screwing back and forth any detached water drops are removed. The arrangement of the two tips is shown in fig. 6.

The method of reading the volumes is as follows: The tips of the burette and the compensator both dip into the same beaker filled with water. This should be of the same type as the one in fig. 4 but of larger dimensions, height about 8—9 cm., diameter about 6 cm. The gas bell, which is of the same dimensions as the one in fig. 4, may be cemented on to the wall of the beaker with de Khotinsky cement. At the start of the analysis the water in the compensator is placed at the mark M by means of the mercury screw, the adjustable table being set at a suitable height, and the screw F on the burette is operated so as to place the level in the gas-siphon at the mark M_1 . For the subsequent readings the mercury screw of the compensator must be left untouched, but the water level in the compensator-tip is placed at the mark M by adjustment of the table, after which the burette screw is operated so as to place the water level in the gas-siphon at M_1 . Thus the reduction factor obviously remains constant during the whole analysis and therefore can be omitted from the calculations. For cases where comparison with measurements from other burettes are needed, a thermometer in the temperature bath is provided.

As it is inconvenient to make the range of movement of the adjustable table greater than 8—10 cm., which corresponds to a temperature difference of less than 1.5°C. , a place with not too variable temperature should be chosen for the apparatus. If nevertheless necessary, the mantle may be heated slightly by the hand or cooled with a wet cloth.

Advisory Remarks.

In conclusion we should add a few remarks on the choice between the different possibilities of construction mentioned above, this choice of course depending on the purpose. First of all we should recommend the use of the compensator in all cases. The extra complication in construction and use is not essential, and it saves hours spent on tedious calculations.

If the apparatus is intended for absorptions only, or if the highest possible accuracy is aimed at, no combustion device should be arranged on the top of the burette. Combustion may then be carried out by explosion, the devices for this being easily improvised. As mentioned above, the explosion method often gives rise to errors, which may be avoided by increasing the amount of oxygen added, or decreasing the amount of gas to be analyzed, or both. If a series of analyses of similar gases is to be carried out, in which case the amount of oxygen necessary may be found once for all by experiments, the explosion method must be preferred on account of its rapidity.

In all other cases, however, combustion in the heated quartz capillary is preferable, and if the highest possible accuracy of the absorptions of CO_2 and O_2 is desired, as will be the case in physiological investigations, the separate combustion pipette should be used. It should be added that if the adjustable table is fixed on the same base as the burette, which is convenient, the mirror image of fig. 7 should be used for the design. Furthermore, in this case the table should be amply large and care should be taken that the siphons of the burette and the combustion pipette, respectively, are being placed at the same height above the laboratory desk. In this way the cost of an extra adjustable table for the combustion pipette can be avoided.

For ordinary use, however, it is more convenient in use and much cheaper to mount the quartz hairpin and the furnace on the burette and its stand. No drawing of this arrangement is given as its design is practically self-evident.

It should perhaps be mentioned that for physiological purposes the accuracy may be increased by the well-known device of enlarging the upper part of the burette, so that it contains

700 out of 1000 parts of the whole volume on a length of about 100 mm., while 300 parts occupy a length of 300 mm., the total volume of the compensator being distributed in a similar way. In that case, however, an adjustment of the mercury in the burette finer than that to be obtained with the syringe will be found necessary. Presumably the best plan will be to move the syringe about 15 mm. from the bottom end of the graduated tube and then to connect the ends with stout rubber tubing, which can be compressed by means of a pinchcock whose base is fixed on the board behind. By this means it ought to be possible to obtain an absolute accuracy of nearly 0.01 per cent. abs., but it should be added that the authors have not tried out this possibility, as the extreme accuracy obtainable by such means has been unnecessary in their current work.

Chemical Laboratory A
Royal Technical High-School, Copenhagen.

References.

- (1) See f. inst. the article by A. KROGH in Abderhaldens Handb. der Biochemischen Arbeitsmethoden 8 (1915) 532.
 - (2) L. DOYÈRE: Annales de chim. et de phys. (3) 28 (1850) 1.
 - (3) A. KROGH: Abderhaldens Handb. der Biochemischen Arbeitsmethoden 8 (1915) 495.
 - (4) Journ. Am. Chem. Soc. 47 (1925) 109.
 - (5) Z. anal. Chem. 80 (1930) 435.
 - (6) For other constructions especially of American origin see f. inst. W. D. TREADWELL: Tabellen und Vorschriften zur quantitativen Analyse (Leipzig und Wien, FRANZ DEUTICKE, 1938) p. 222.
 - (7) P. B. REHBERG: Biochemical Journ. 19 (1925) 270.
-

